

SPECYFIKACJA MECHANICZNA

światlik rurowy do podstawy 250

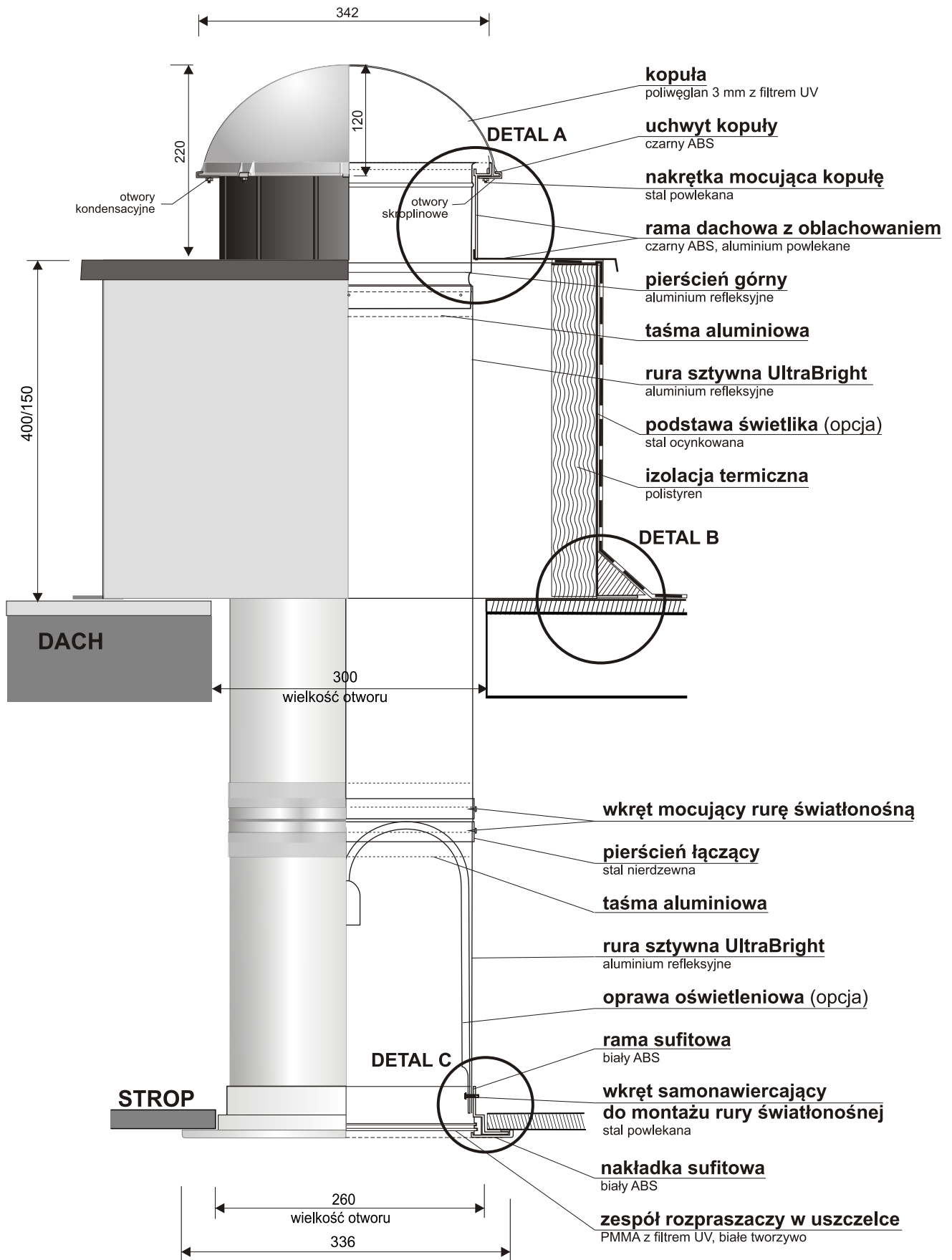

DETAL A

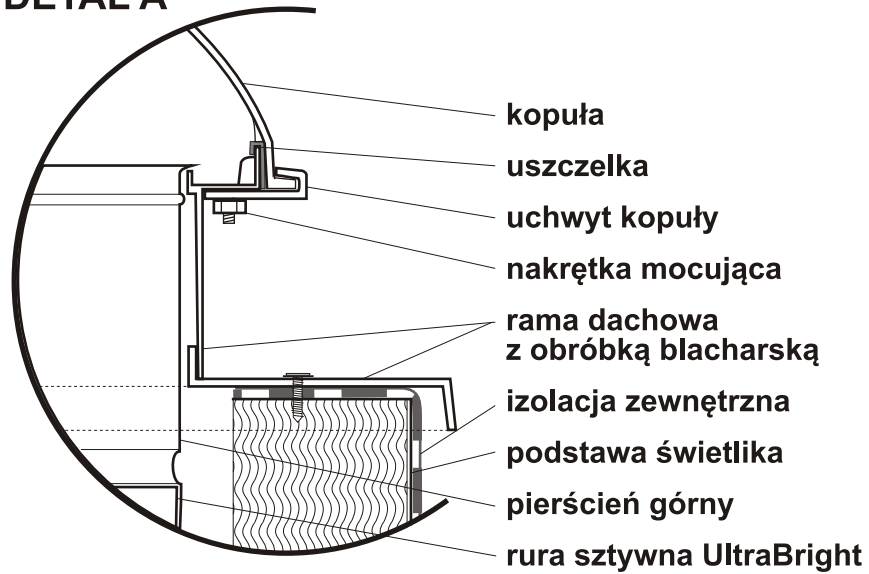

DETAL B

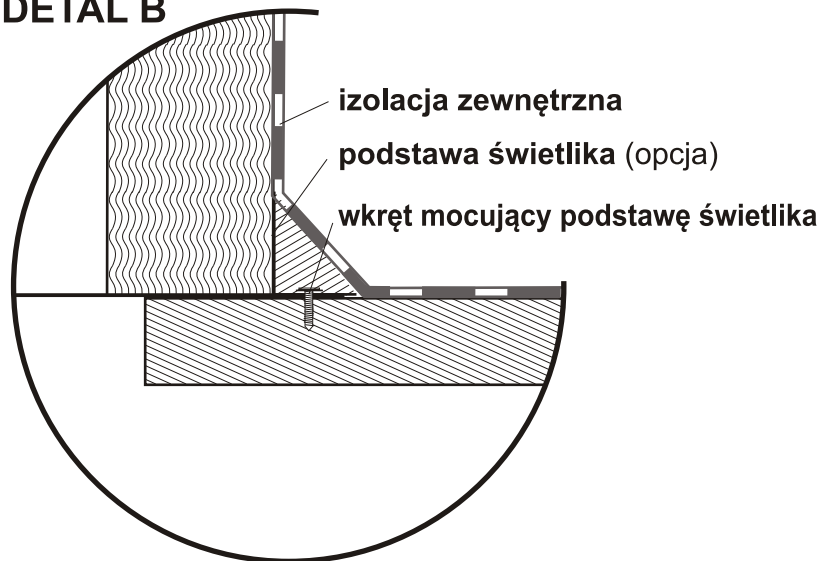

DETAL C

