

# SPECYFIKACJA MECHANICZNA

światlik rurowy do podstawy 850

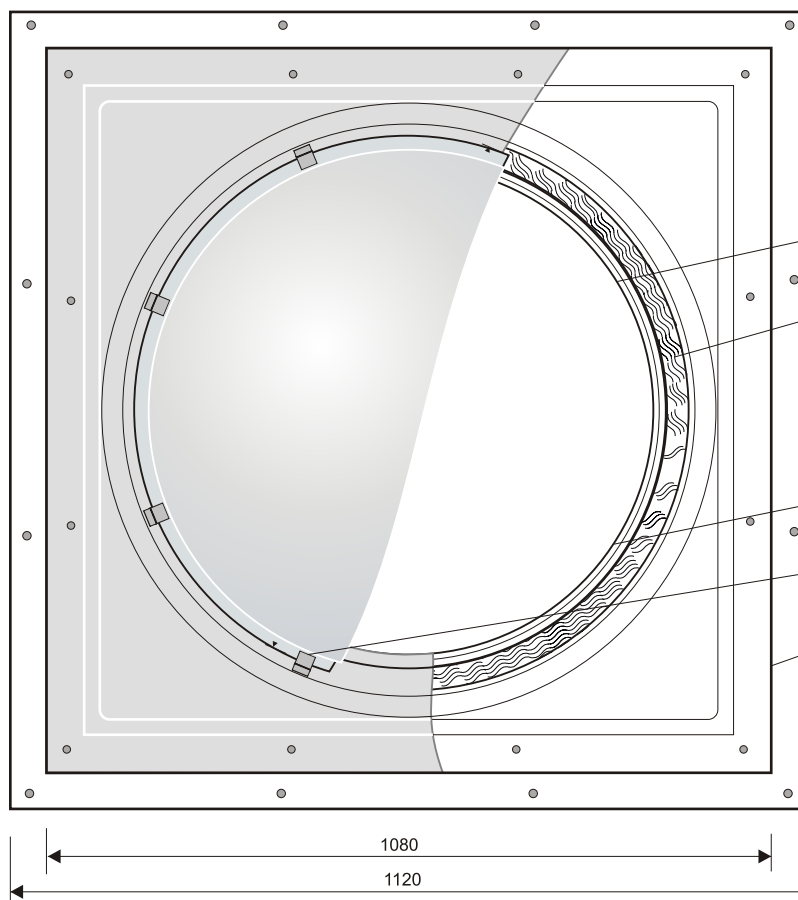

### DETAL A

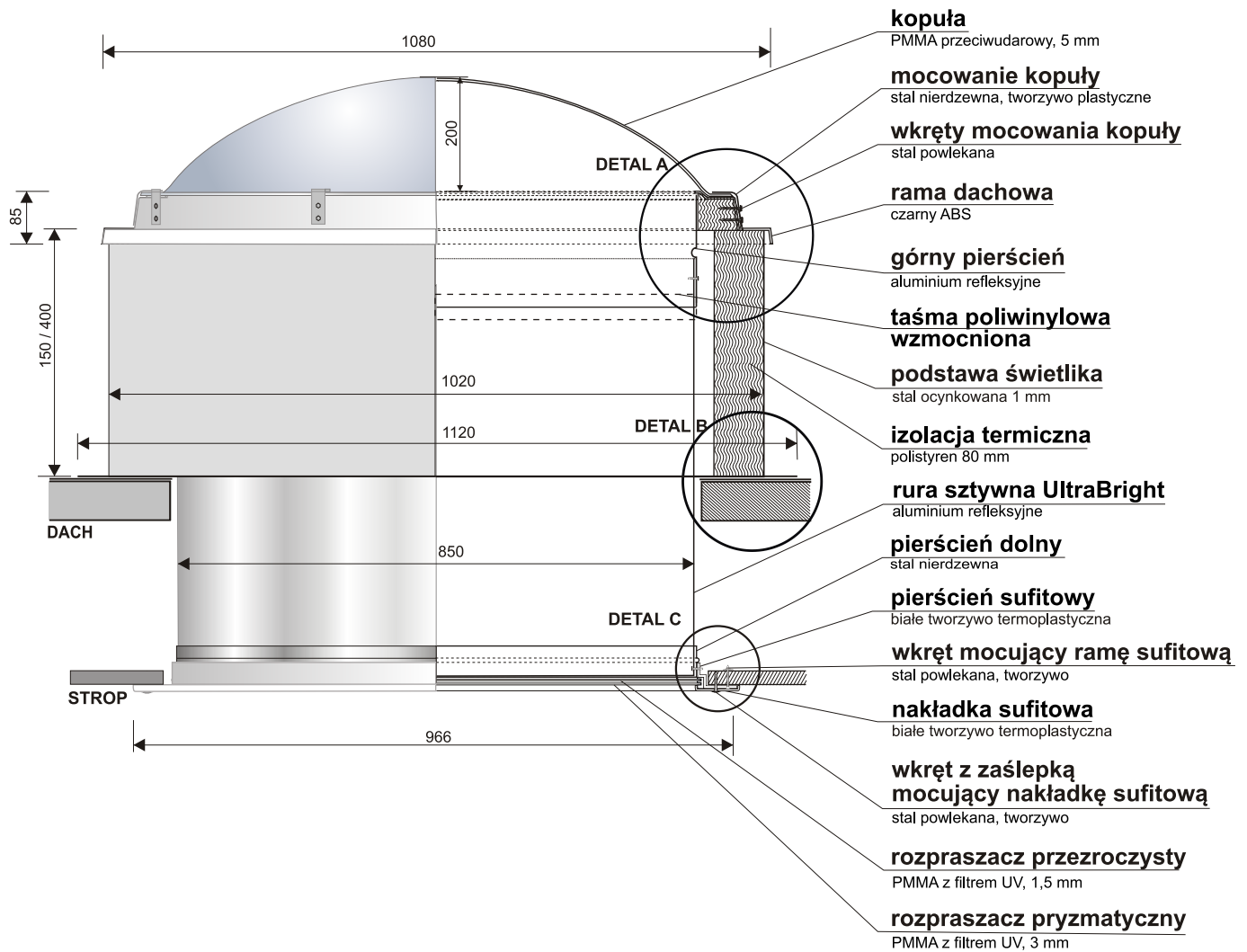
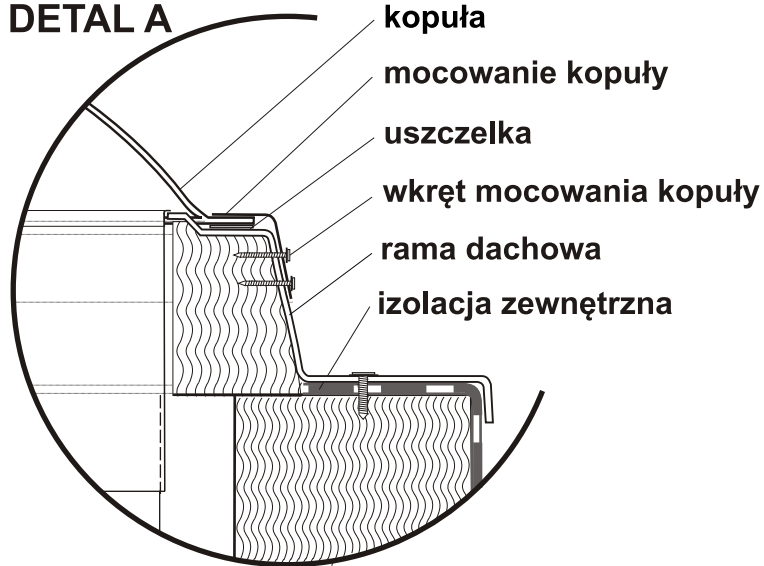

### DETAL B

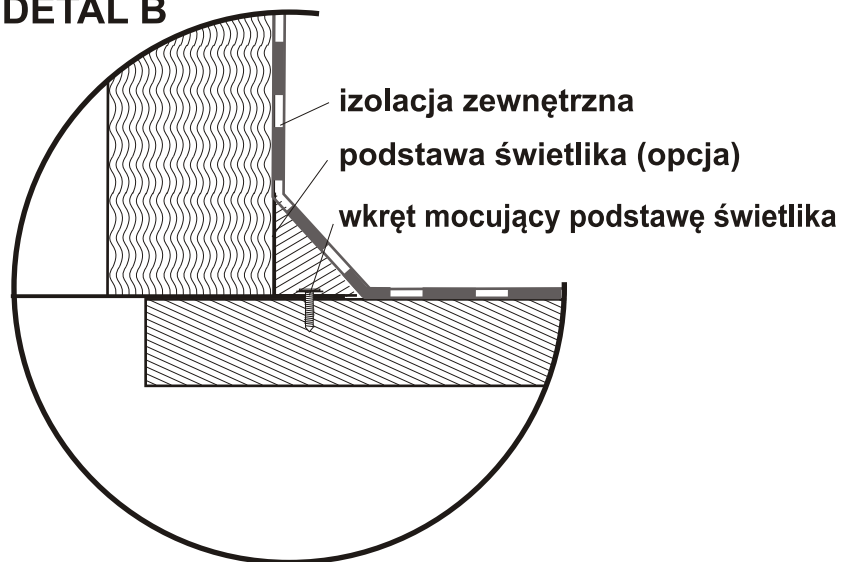

### DETAL C

